

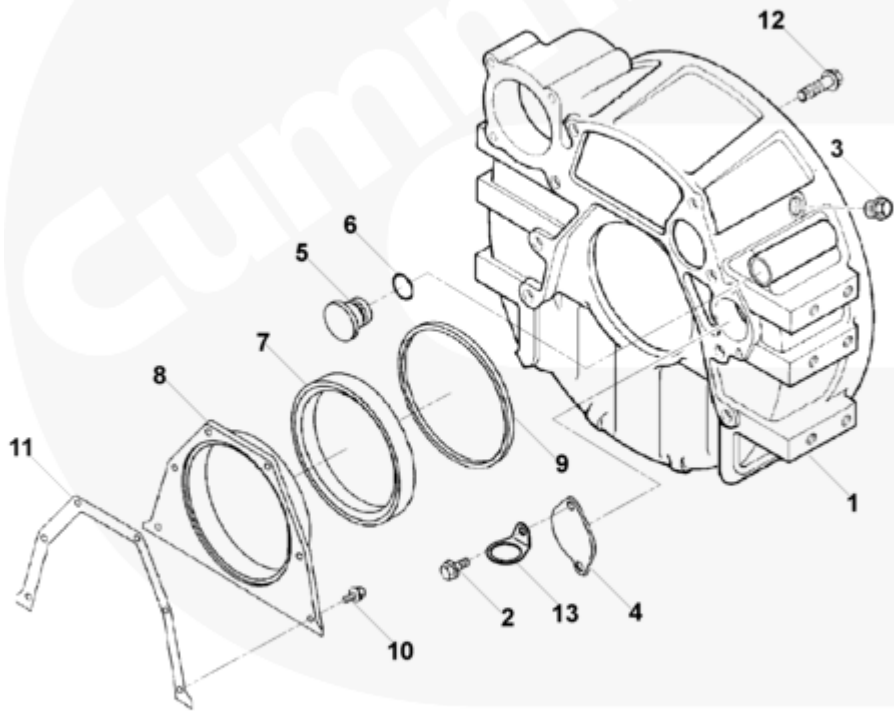

## Parts Catalog - Option Detail

Electronic Parts Catalog - Option Detail				
Option	Group	Graphic	Film Card	Date
FH9002-08	16.01	fh902go	T	25-FEB-08
<b>Engines</b>	4B3.9, 6A3.4, 6B5.9, B GAS INTERNATIONAL CM556, B4.5, B4.5 CM2350 B129B, B4.5 CM2350 B146C, B4.5 CM2350 B147B, B4.5 RGT, B4.5S, B5.9 G, B5.9 GAS PLUS CM556, B5.9 LPG, B5.9 LPG PLUS CM556, B6.7 CM2350 B121B, B6.7 CM2350 B135B, B6.7 CM2350 B136C, B6.7 CM2350 B148B, B6.7 G CMOH6.0 B125, B6.7N CM2380 B150B, B6.7S, F3.8 CM2350 F120B, F3.8 CM2350 F128C, F3.8 CM2350 F132B, F3.8 F102, G3.9, G5.9, G5.9 CM558, ISB (CHRYSLER), ISB CM2150, ISB CM2150 E, ISB CM550, ISB CM850, ISB/ISD4.5 CM2150 B119, ISB/ISD4.5 CM2150 SN, ISB/ISD6.7 CM2150 B120, ISB/ISD6.7 CM2150 SN, ISB/ISD6.7 CM2880 B126, ISB3.9 CM2220 B107, ISB4.5 CM2150, ISB5.9G CM2180, ISB6.7 2010 DCX PICKUP, ISB6.7 2013 DCX CHASSIS CAB, ISB6.7 CM2150 SQ, ISB6.7 CM2250, ISB6.7 CM2350 B101, ISB6.7 CM2350 B103, ISB6.7 CM2350 B142, ISB6.7 CM2670 B153B, ISB6.7 G CM2180 B118, ISBE CM2150, ISBE CM800, ISBE2/ISBE3 CM850, ISBE4 CM850, ISD4.5 CM2150, ISD6.7 CM2880 D101, ISF2.8 CM2220, ISF2.8 CM2220 AN, ISF2.8 CM2220 EC, ISF2.8 CM2220 ECF2, ISF2.8 CM2220 F101, ISF2.8 CM2220 F117, ISF2.8 CM2220 F122, ISF2.8 CM2220 F126, ISF2.8 CM2220 F129, ISF2.8 CM2220 IAN, ISF3.8 CM2220, ISF3.8 CM2220 AN, ISF3.8 CM2220 F103, ISF3.8 CM2220 F110, ISF3.8 CM2220 F116, ISF3.8 CM2220 F134B, ISF3.8 CM2220 IAN, ISF3.8 CM2350 F109, ISF4.5 CM2220 F123, ISG11 CM2880 G106, ISG11 CM2880 G108, ISG12 CM2880 G107, ISG12 CM2880 G109, ISG12 G CMOH6.0 G111, QSB3.9 30 CM550, QSB3.9 CM2880 B138, QSB4.5 30 CM550, QSB4.5 CM2150 B108, QSB4.5 CM2250 B131, QSB4.5 CM2250 EC, QSB4.5 CM2350 B106, QSB4.5 CM2350 B122			



fh902go

[SMALL](#) | [MEDIUM](#) | [LARGE](#)

Cart	Ref No	Part Number	Part Description	Required	Remarks
<a href="#">View My Cart</a>					
		<a href="#">FH9002-08</a>	Flywheel Housing		<a href="#">Flywheel Housing...(More)</a>
					Wet/Dry Clutch: Dry
					Housing Material: Aluminum
					SAE Size or Type: SAE 3
					Starter Mount SAE: SAE #1 -
					3 Bolt 90 Degree
					Starter Mount Thread Type:
					Metric
					Starter Quadrant: First

					Starter Pad Offset from RFOB
					(mm): 0.00
					Starter Mounting Hole
					Diameter (mm): 88.90
					Mount Type: Pad
					Engine Mounting Hole
					Dimension: M12 X 1.75 - 6H
					Number of Mount Holes: 12
					Engine Mount Top Hole +/- CR
					C/L (mm): 82.5
					Tachometer Sensor Location:
					Fourth
					Tachometer Size: 3/4 - 16 UNF
					Tachometer Count: 1
					Transmission Mounting Holes
					Count/Thread: 12 - M10 X 1.50
					X 25
					Starter Pad +/- CR C/L Y Axis
					(mm): 147.31
					Starter Pad +/- CR C/L X Axis
					(mm): 158.53
					Starter Bore Angle (Deg): 47
					Flywheel Housing Attachment
					Provision: Cylinder Block
					Starter Center Distance:
					216.407
					Doweled for Oil Pan: No
					Not to be Used With Low Mount
					Rear out Turbo Locations.

<input type="checkbox"/>	1	<a href="#">3937426</a>	Flywheel Housing	1	
<input type="checkbox"/>	2	<a href="#">3912072</a>	Self Tapping Metal Screw	2	M8 x 1.25 x 15
<input type="checkbox"/>	3	<a href="#">3904181</a>	Threaded Plug	1	3/4 - 16 UNF
<input type="checkbox"/>	4	<a href="#">3908095</a>	Cover Plate	1	
<input type="checkbox"/>	5	<a href="#">3910248</a>	O-Ring Plug	1	
<input type="checkbox"/>	6	<a href="#">3910260</a>	O-Ring Seal	1	
<input type="checkbox"/>		<a href="#">3357844</a>	Rear Cover	1	
<input type="checkbox"/>	7	<a href="#">3970548</a>	Oil Seal	1	
<input type="checkbox"/>	8	<a href="#">3936895</a>	Rear Cover	1	
<input type="checkbox"/>	9	<a href="#">3912473</a>	Rectangular Ring Seal	1	
<input type="checkbox"/>	10	<a href="#">3991306</a>	Hexagon Flange Head Cap Screw	6	M8 x 1.25 x 15
	11	<a href="#">3938159</a>	Rear Cover Gasket	1	
<input type="checkbox"/>	12	<a href="#">3920447</a>	Hexagon Flange Head Cap Screw	8	M12 X 1.75 X 40.
<input type="checkbox"/>	13	<a href="#">3928989</a>	Clip	1	
<input type="checkbox"/>		<a href="#">4089342</a>	Crankshaft Seal Kit	A/R	
<input type="checkbox"/>	7	<a href="#">3970548</a>	Oil Seal	1	
		<a href="#">3909409</a>	Seal Installation Tool	1	
<input type="checkbox"/>		<a href="#">4089425</a>	Seal Installation Tool	1	
<input type="checkbox"/>		<a href="#">4940231</a>	Seal Installation Tool	1	